

❖ With standard, off-the-shelf fixturing kits for the OW 19 you can weld microfits and VCR glands.

ORBIWELD 19

Closed orbital weld head for tube diameters from 3 - 19.05 mm (0.118 - 0.750"). Extremely small yet rugged design provides very high duty cycle production rates through an integral water-cooled body design.

A wide range of very useful applications especially in

- Semiconductor industry
- Aircraft, aerospace
- Pharmaceutical industry
- High-purity water installations
- Laboratory, instrumentation
- High production rate part manufacturing
- Portable on-site repair and installation

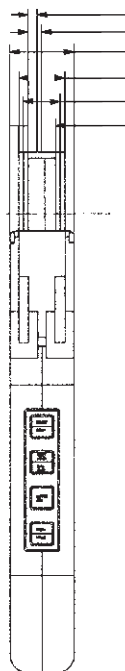
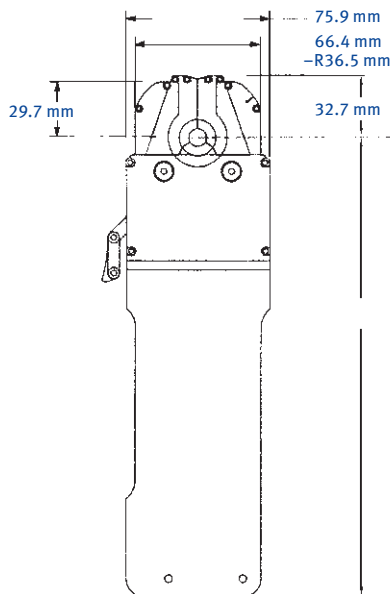

❖ Built-in keypad in the handle

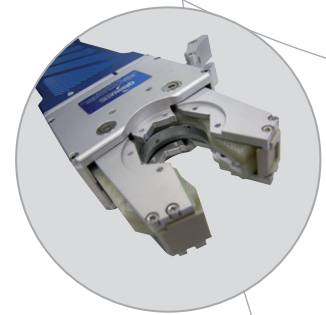

❖ Easy-to-use triple clamping mechanism

With the built-in keypad in the handle all necessary commands can be given to the power-source without using an additional remote control. With the easy-to-use triple clamping mechanism you are able to quickly and positively fix the head onto the weld joint under extremely narrow or inaccessible conditions. Because of the clamp design no parts extend beyond the shape of the head body, even in the fully-open position. Furthermore, with the very accurate and solid clamping design, an exact alignment and positive fixturing of the welded parts is repeatedly assured.

The technical data are not binding. They are not warranted characteristics and are subject to change. Please consult our general conditions of supply.

© Orbitalum Tools GmbH (09.2009)



Orbitalum Tools GmbH, Josef-Schüttler-Str. 17, 78224 Singen, Germany

Sales Contact:
Tel. +49 (0) 77 31 792-786 up to -790
Fax +49 (0) 77 31 792-524
tools@orbitalum.com
www.orbitalum.com

Repair Service:
Floesser Weg 17
35418 Buseck, Germany
Tel. +49 (0) 64 08 08 90 26-12
Fax +49 (0) 64 08 08 90 26-50